

# CrystaLatch™ 1x4 5W High Power Series Fiber Optical Switch



(SM, PM, Unidirectional, Bidirectional, High Power)

(Protected by U.S. patents 7224860, 6757101, 6577430 and pending patents)

DATASHEET

BUY NOW



## Features

- High Speed
- Non-Mechanical
- High Reliability
- Fail-Safe Latching
- Low Insertion Loss
- Rugged
- Compact
- Cost Effective
- Direct Low Voltage Drive

## Applications

- Optical Signal Routing
- Network Protection
- Burst Switching
- Configurable Add/Drop
- Signal Monitoring
- Instrumentation

The CL 1x4 5W High power Series fiber optical switch connects optical channels by redirecting an incoming optical signal into a selected output fiber. This is achieved using patented non-mechanical configurations and activated via an electrical control signal. Latching operation preserves the selected optical path after the drive signal has been removed. The CL 1x4 5W High power series fiber optic switch feature low insertion loss, high extinction ratio, high channel isolation, and extremely high reliability and repeatability. It is designed to meet the most demanding switching requirements of continuous operation without failure, longevity, operation under shock/vibration environment and large temperature variations, and fast response time.

The switch also has build-in circulator and isolator functions. Electronic driver is available for this series of switches.

The magneto-optical crystals used in the CL switches have no fatigue nor drift effect.

## Specifications

Parameter	Min	Typical	Max	Unit	
Operation Wavelength <sup>[1]</sup>	1520	1550	1580	nm	
	1295	1310	1325	nm	
Insertion Loss <sup>[2]</sup>		1.5	2.2	dB	
Crosstalk <sup>[2]</sup>	Bidirectional Series	Single Stage	25		dB
		Dual Stage	50		dB
	Unidirectional Series	Single Stage	25		dB
		Dual Stage	50		dB
Return Loss <sup>[2]</sup>	50	55		dB	
PDL (SM Series Switch only)		0.15	0.25	dB	
Polarization Mode Dispersion			0.2	ps	
Optical Switching Speed (Rise, Fall)	5		10	μs	
Repetition Rate		2K		Hz	
Durability	10 <sup>15</sup>			cycle	
Optic Power Handling			5	W	
Operating Temperature	-5		70	°C	
Storage Temperature	-40		85	°C	
Fiber Type	SMF-28, or equivalent				

### Notes:

- [1]. Agiltron can achieve same SPEC at L band
- [2]. Measured without connectors.

**Legal notices:** All product information is believed to be accurate and is subject to change without notice. Information contained herein shall legally bind Agiltron only if it is specifically incorporated into the terms and conditions of a sales agreement. Some specific combinations of options may not be available. The user assumes all risks and liability whatsoever in connection with the use of a product or its application.

Rev 03/14/24

# CrystaLatch™ 1x4 5W High Power Series Fiber Optical Switch



(SM, PM, Unidirectional, Bidirectional, High Power)

(Protected by U.S. patents 7224860, 6757101, 6577430 and pending patents)

## DATASHEET

### Mechanical Dimensions (Unit: mm)

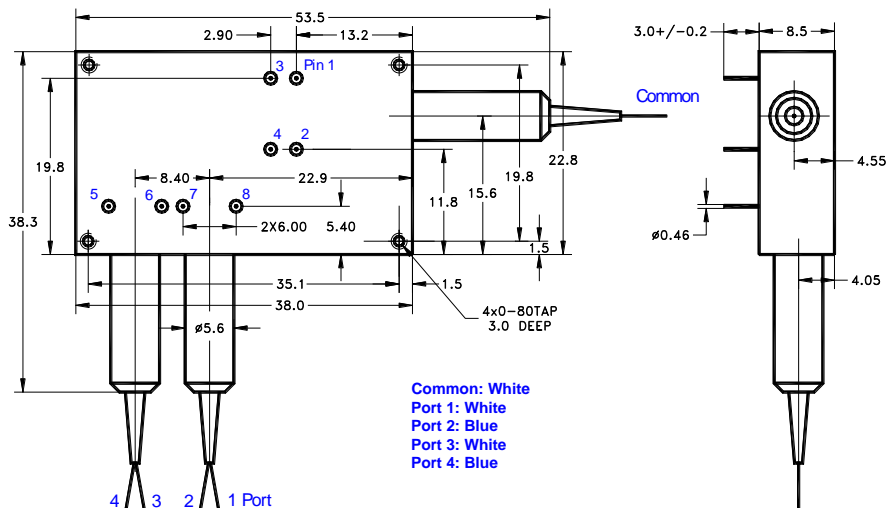

\*Product dimensions may change without notice. This is sometimes required for non-standard specifications.

### Electrical Driving Information

Each switching point is actuated by applying a voltage pulse. Applying one polarity pulse, one light path will be connected and latched to the position. Applying a reversed polarity pulse, another light path will be connected and latched to the position after pulse removed.

Parameter	Minimum	Typical	Maximum	Unit
Resistance (each group)	15	18	22	Ω
Switch Voltage	2.25	2.5	2.75	V
Pulse Duration	0.2	0.3	0.5	ms

Driving kit with USB and TTL interfaces and Windows™ GUI is available. We also offer RS232 interface as an option – please contact Agiltron sales.

### Bidirectional Series 1x4, or 4x1 Switch Driving Table

#### Single Stage

Optical Path	Pin Group 1		Pin Group 2	
	Pin 1	2	3	4
Common ↔ Port 1	+ [1]	0	+	0
Common ↔ Port 2	0	+	0	+
Common ↔ Port 3	+	0	0	+
Common ↔ Port 4	0	+	+	0

[1]. "+": 2.25~2.75 V pulse

#### Dual Stage

Optical Path	Pin Group 1		Pin Group 2		Pin Group 3		Pin Group 4	
	Pin 1	2	3	4	5	6	7	8
Common ↔ Port 1	+ [1]	0	+	0	0	+	+	0
Common ↔ Port 2	0	+	0	+	0	+	+	0
Common ↔ Port 3	+	0	0	+	+	0	0	+
Common ↔ Port 4	0	+	+	0	+	0	0	+

[1]. "+": 2.25~2.75 V pulse

# CrystaLatch™ 1x4 5W High Power Series Fiber Optical Switch



(SM, PM, Unidirectional, Bidirectional, High Power)

(Protected by U.S. patents 7224860, 6757101, 6577430 and pending patents)

## DATASHEET

### Unidirectional Series 1x4 Switch Driving Table

#### Single Stage

Optical Path	Pin Group 1		Pin Group 2	
	Pin 1	2	3	4
Common → Port 1	+ <sup>[1]</sup>	0	+	0
Common → Port 2	0	+	0	+
Common → Port 3	+	0	0	+
Common → Port 4	0	+	+	0

[1]. "+": 2.25~2.75 V pulse

#### Dual Stage

Optical Path	Pin Group 1		Pin Group 2		Pin Group 3		Pin Group 4	
	Pin 1	2	3	4	5	6	7	8
Common → Port 1	+ <sup>[1]</sup>	0	+	0	0	+	+	0
Common → Port 2	0	+	0	+	0	+	+	0
Common → Port 3	+	0	0	+	+	0	0	+
Common → Port 4	0	+	+	0	+	0	0	+

[1]. "+": 2.25~2.75 V pulse

### Unidirectional Series 4x1 Switch Driving Table

#### Single Stage

Optical Path	Pin Group 1		Pin Group 2	
	Pin 1	2	3	4
Port 1 → Common	0	+ <sup>[1]</sup>	0	+
Port 2 → Common	+	0	+	0
Port 3 → Common	0	+	+	0
Port 4 → Common	+	0	0	+

[1]. "+": 2.25~2.75 V pulse

#### Dual Stage

Optical Path	Pin Group 1		Pin Group 2		Pin Group 3		Pin Group 4	
	Pin 1	2	3	4	5	6	7	8
Port 1 → Common	0	+ <sup>[1]</sup>	0	+	+	0	0	+
Port 2 → Common	+	0	+	0	+	0	0	+
Port 3 → Common	0	+	+	0	0	+	+	0
Port 4 → Common	+	0	0	+	0	+	+	0

[1]. "+": 2.25~2.75 V pulse

#### Note:

The driving voltage value is transient voltage with a full load. The driver circuitry needs to provide sufficient current (~300mA) during the switching. Inside the switch core is an electromagnet with a residual magnetic field. The residual magnetic field will be established when an electrical current flows in one direction through the coil for a sufficiently long period. The residual magnetic field latches the switch state even without applying a voltage (the current flow stopped). Flowing a current in the opposite direction for a sufficient time changes the switch stage by establishing a reversal magnetic field. The coil is forgiving to the driver unless one burns it by applying a higher voltage or a current for too long (day). The switch can also be operated at high repetition rates of kHz, where the residual magnetic field may not be fully established.

## Functional Diagram

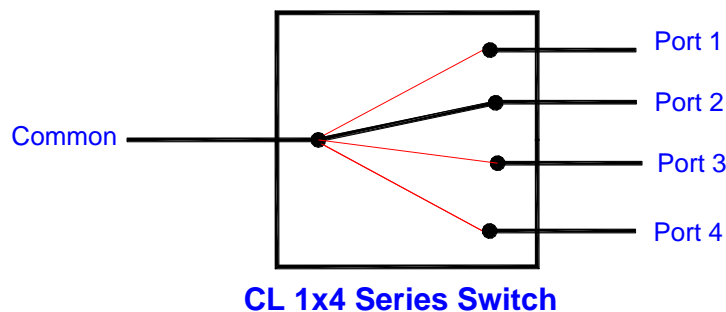

# CrystaLatch™ 1x4 5W High Power Series Fiber Optical Switch

(SM, PM, Unidirectional, Bidirectional, High Power)

(Protected by U.S. patents 7224860, 6757101, 6577430 and pending patents)



## DATASHEET

### Typical Switching Response

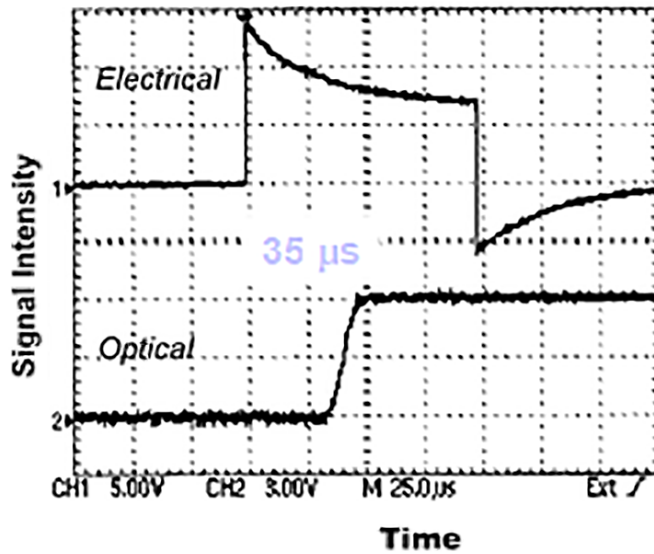

### Typical Loss Change of 1x2 vs Switching Numbers

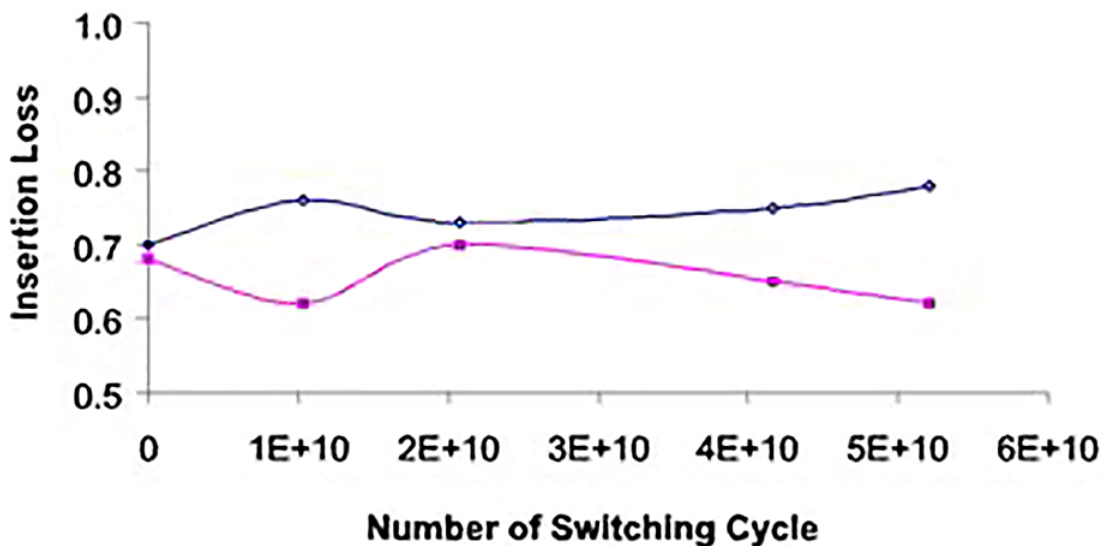

# CrystaLatch™ 1x4 5W High Power Series Fiber Optical Switch



(SM, PM, Unidirectional, Bidirectional, High Power)

(Protected by U.S. patents 7224860, 6757101, 6577430 and pending patents)

## DATASHEET

### Ordering Information

Prefix	Type	Wavelength	Switch	Package	Fiber Type	Fiber Cover	Fiber Length	Connector
CLHP- <sup>[1]</sup>	1x4 = 14	1310 = 3	Single Stage+5W = 3	Standard = 2	SMF-28 = 1	Bare fiber = 1	0.25m = 1	None = 1
CLHB- <sup>[2]</sup>	4x1 = 41	1550 = 5	Dual Stage+5W = 4	Special = 0	Special = 0	900 μm tube = 3	0.5m = 2	FC/PC = 2
	1x3 = 13	Special = 0	Special = 0			Special = 0	1.0m = 3	FC/APC = 3
	3x1 = 31						Special = 0	SC/PC = 4
	Special = 00							SC/APC = 5
								ST/PC = 6
								LC/PC = 7
								Duplex LC/PC = 8
								LC/APC = A
								LC/UPC = U
								Special = 0

[1]. **CLHP**: CrystaLatch 1x4 5W High Power Switch.

[2]. **CLHB**: CrystaLatch 1x4 5W High Power Bidirectional Switch.

#### Fiber Core Alignment

Note that the minimum attenuation for these devices depends on excellent core-to-core alignment when the connectors are mated. This is crucial for shorter wavelengths with smaller fiber core diameters that can increase the loss of many decibels above the specification if they are not perfectly aligned. Different vendors' connectors may not mate well with each other, especially for angled APC.

#### Fiber Cleanliness

Fibers with smaller core diameters (<5 μm) must be kept extremely clean, contamination at fiber-fiber interfaces, combined with the high optical power density, can lead to significant optical damage. This type of damage usually requires re-polishing or replacement of the connector.

#### Maximum Optical Input Power

Due to their small fiber core diameters for short wavelength and high photon energies, the damage thresholds for device is substantially reduced than the common 1550nm fiber. To avoid damage to the exposed fiber end faces and internal components, the optical input power should never exceed 20 mW for wavelengths shorter 650nm. We produce a special version to increase the how handling by expanding the core side at the fiber ends.

# CrystaLatch™ 1x4 5W High Power Series Fiber Optical Switch

(SM, PM, Unidirectional, Bidirectional, High Power)

(Protected by U.S. patents 7224860, 6757101, 6577430 and pending patents)



## DATASHEET

### Driver Design Example for 1x4

A recommended +5VDC powered driving circuit is provided. The resistor network R1~R8 is to suppress the driving signal's voltage level to meet the "switch voltage" requirements. In specific applications, users can use lower voltage to eliminate the R1~R8. The Q1~Q8 is the control signal from either a function generator or a microcontroller general purpose I/O. The Q1-Q8 switching speed must meet the specific MOSFET switching requirement and CL 1x4 Switch specific requirement. Usually, the control signal speed is  $\leq 2\text{kHz}$ .

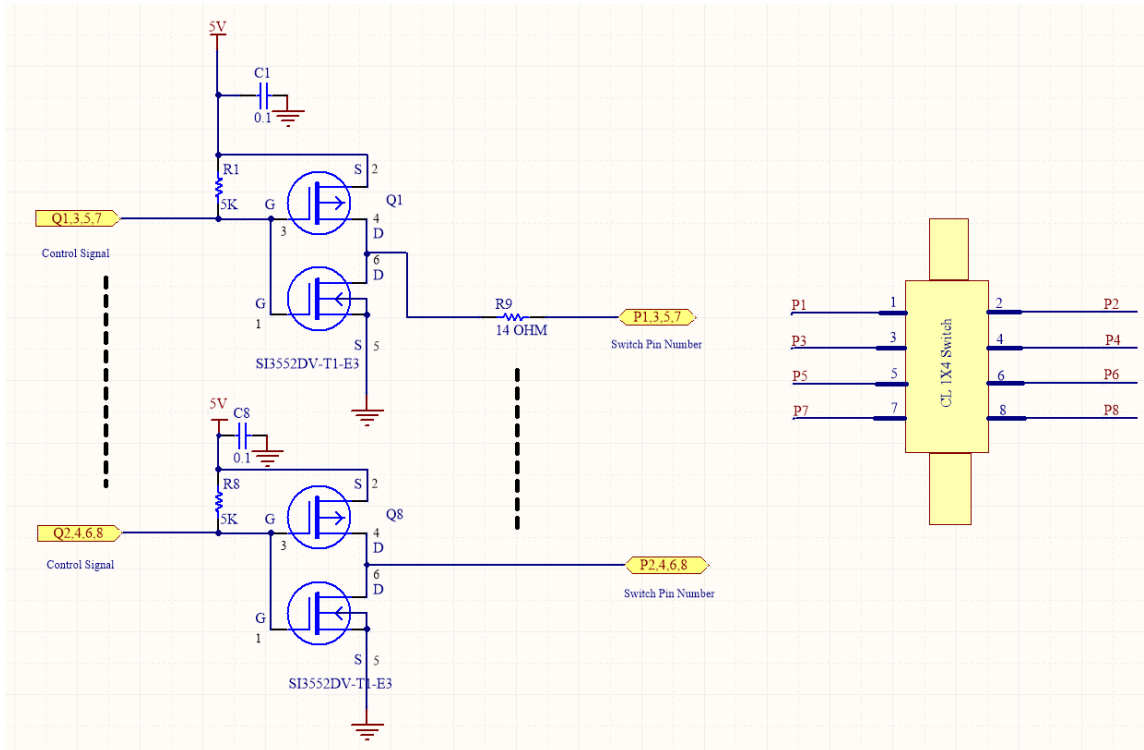

Usually, a clean power supply source will be sufficient. However, decoupling capacitors for the transistor supply rail are recommended depending on different applications. Minimum the current loop on the switching circuits will minimize the switching noise. For other layout recommendations, please refer to books or application notes from the IC manufacturer.